

Received 26 June 2017; revised 20 October 2017 and 12 January 2018; accepted 19 February 2018.
Date of publication 12 March 2018; date of current version 28 March 2018.

Digital Object Identifier 10.1109/JTEHM.2018.2811458

An Alternative Myoelectric Pattern Recognition Approach for the Control of Hand Prostheses: A Case Study of Use in Daily Life by a Dismelia Subject

ENZO MASTINU¹, (Student Member, IEEE), JOHAN AHLBERG²,
EVA LENDARO¹, (Student Member, IEEE), LISELOTTE HERMANSSON^{3,4},
BO HÅKANSSON¹, AND MAX ORTIZ-CATALAN^{1,5}, (Member, IEEE)

¹Department of Electrical Engineering, Chalmers University of Technology, 412 58 Gothenburg, Sweden

²Kungliga Tekniska Högskolan, 114 28 Stockholm, Sweden

³University Health Care Research Center, Faculty of Medicine and Health, Örebro University, 702 81 Örebro, Sweden

⁴Department of Prosthetics and Orthotics, Faculty of Medicine and Health, Örebro University, 702 81 Örebro, Sweden

⁵Integrum AB, 431 37 Mölndal, Sweden

CORRESPONDING AUTHOR: M. ORTIZ-CATALAN (maxo@chalmers.se)

This work was supported by the Swedish Research Council (Vetenskapsrådet), Stiftelsen Promobilia, VINNOVA, and the European Commission (H2020, DeTOP project).

ABSTRACT The functionality of upper limb prostheses can be improved by intuitive control strategies that use bioelectric signals measured at the stump level. One such strategy is the decoding of motor volition via myoelectric pattern recognition (MPR), which has shown promising results in controlled environments and more recently in clinical practice. Moreover, not much has been reported about daily life implementation and real-time accuracy of these decoding algorithms. This paper introduces an alternative approach in which MPR allows intuitive control of four different grips and open/close in a multifunctional prosthetic hand. We conducted a clinical proof-of-concept in activities of daily life by constructing a self-contained, MPR-controlled, transradial prosthetic system provided with a novel user interface meant to log errors during real-time operation. The system was used for five days by a unilateral dismelia subject whose hand had never developed, and who nevertheless learned to generate patterns of myoelectric activity, reported as intuitive, for multi-functional prosthetic control. The subject was instructed to manually log errors when they occurred via the user interface mounted on the prosthesis. This allowed the collection of information about prosthesis usage and real-time classification accuracy. The assessment of capacity for myoelectric control test was used to compare the proposed approach to the conventional prosthetic control approach, direct control. Regarding the MPR approach, the subject reported a more intuitive control when selecting the different grips, but also a higher uncertainty during proportional continuous movements. This paper represents an alternative to the conventional use of MPR, and this alternative may be particularly suitable for a certain type of amputee patients. Moreover, it represents a further validation of MPR with dismelia cases.

INDEX TERMS Prosthetic control, electromyogram (emg), myoelectric pattern recognition (MPR), dismelia, assessment of capacity for myoelectric control (ACMC).

ACRONYMS

EMG	Electromyography
DC	Direct Control
MPR	Myoelectric Pattern Recognition
ACMC	Assessment of Capacity for Myoelectric Control

I. INTRODUCTION

Given the technological progress in robotics and component miniaturization, it is now technically possible to create a mechatronic arm that has similar functionality and dexterity to its biological counterpart [1]. However, the general

amputee population is still far from benefitting from this technology due to the challenges present at the interface between human and machine. For this reason, today commercial scene still offers only limited options to compensate for the lack of a limb; simple prosthetic grippers cosmetically shaped as real hands are commonly adopted due to their ease of use and reliability. These devices make use of electromyographic (EMG) signals from an agonist–antagonist pair of residual muscles, to proportionally control the speed with one degree of freedom in a one-input-one-movement approach. This solution is known as direct control (DC) and has the limitation that open and close of the terminal device are the only movements commonly enabled. In contrast, the most technologically advanced prosthetic hands on the market allow for different hand postures (or grips), which the user can select in a sequential or semi-sequential fashion. In order to switch among grips the user needs to perform certain predefined muscles contractions, such as co-contraction or multiple-pulses over the selected pair of channels for DC. This way of controlling the prosthesis is not intuitive and demands training and practice for the user to become familiar with the switching mechanisms, possibly explaining why efficacy outcomes strongly vary from subject to subject.

To overcome the constraints imposed by DC, researchers have focused on myoelectric pattern recognition (MPR). It has been widely shown that machine learning algorithms can be trained to recognize the patterns of muscles activation enclosed in the EMG signals, and to decode the motor intention of the user. This approach brings the advantage of providing a more intuitive control, where the learning burden is shared between the user and the machine.

II. BACKGROUND AND RELATED WORK

The investigations of MPR started in the mid-1960's at the Rehabilitation Engineering Center of Philadelphia, and a complete report was published later by Wirta *et al.* [1]. For the first time, a MPR system, composed by a simple weighted network of resistors, was able to recognize different movements taking as input EMG activity recorded simultaneously from different channels. Herberts *et al.* [2], reported a similar, pure analogic MPR system applied for the simultaneous control of a three DoF prosthesis. Shortly after, the advent of microcontroller units brought a crucial increase in the potential of any portable device, including prosthetic controllers. The first attempt of a MCU-based MPR system is dated 1977, from Graupe *et al.* [3]. It was able to perform real-time autoregressive analysis for motions classification and to properly actuate a robotic device. The feasibility of embedded MPR systems has been confirmed more recently by others [4]–[8], albeit not tested in daily life outside controlled environments. To date, there is only a commercially available MPR system (Complete Control, COAPT).

MPR tests in controlled environments using pre-recorded data (offline), as well as conducted in real-time, show an acceptable level of classification accuracy, and overall functionality [9]. Smith *et al.* [10] and Jiang *et al.* [11], showed

the ability of a MPR approach to outperform the standard DC using computer-based assessment tools. However, these results differ when tested by patients in real world settings [12], [13]. A gap seems to exist between laboratory results, and what patients experience while performing activities of daily life. A major contributor to this divergence is certainly the difficulty of designing tools for functionality assessment able to represent and translate results from a controlled environment to a more practical scenario [14]. Further, controlled laboratory conditions usually do not present disturbances in EMG signals that normally arise from electrodes applied on the surface of the skin, namely motion artifacts, electrode displacements, skin impedance changes, cross-talk between muscles, and electromagnetic interference. Invasive signal acquisition has proved to reduce the aforementioned drawbacks of surface EMG allowing for reliable movement discrimination [10], [15], even for long-term implantation [16], [17]. Unfortunately, costs and strict inclusion criteria preclude a massive diffusion of invasive solutions. Up to date, the limitations of surface EMG and MPR continue to hinder their clinical application and their commercial appeal.

A stronger clinical translation of MPR techniques is therefore needed to close the gap between controlled environment tests and daily experience, together with methods to assess the functionality of these approaches. In this study, we investigated the functionality of a non-invasive MPR system in an out-of-the-lab environment. We provided a transradial subject with a custom-made MPR system to control a commercially available multi-grip prosthetic hand. We proposed novel approaches to facilitate the switching mechanism between grips, and to estimate real-time accuracy. The subject utilized the prosthetic system for five consecutive days in his daily life environment while classification and error data was continuously stored. The collected data allowed subsequent analysis for common errors and real-time accuracy. The selected subject was a dysmelia case, who despite never developed a hand, was able to create and use “intuitive” muscle contractions to control the prosthetic device.

III. METHODS

A. MYOELECTRIC PATTERN RECOGNITION IN A DYSMELIA SUBJECT

This study was approved by the Swedish Regional Ethics Committee in Gothenburg (595-16). The pilot subject was a dysmelia case for whom the hand failed to form and had a stump equivalent to a one-third transradial amputation. The subject had used conventional myoelectric prosthesis for approximately twenty years. Since the viability of MPR in congenital amputees is still controversial, we performed preliminary experiments to verify the possibility of intuitive control. The viability of MPR was assessed in real-time using a virtual reality test, namely the Motion Test [18]. The Motion Test requires the subject to perform movements randomly prompted on a screen. Twenty correct predictions

had to be achieved within ten seconds to consider a task completed [19].

The electrode placement and the target movements for MPR were determined by a brute-force approach where multiple combinations were iteratively and exhaustively examined based on the results of the Motion Test. These tests were done using high-density surface EMG recordings (4x8 electrodes arrays) and the BioPatRec software, an open source research platform implemented in Matlab (Mathworks, USA) [19]. The movements studied were hand open and close, wrist flexion and extension, wrist supination and pronation, pointer posture, fine grip and side grip (Figure 2). Only electrode combinations with a maximum number of eight bipolar channels were considered viable for the next step of this study, the take-home MPR system.

Motion tests were done in two separate six-day sessions. The first session was used to determine the two best performing configurations. In the second session, we identified the best of these two configurations to be used in the everyday life experiment. Each day was organized as follows: two tests, one in the morning and one in the evening, each composed of three recording sessions to improve subject familiarity and to train the MPR algorithm, and one evaluation test. The subject sat in front of a computer and asked to perform, per movement, three contractions alternated with three rest periods, three seconds each. The last recording session was used to train a Linear Discriminant Analysis (LDA) classifier. This algorithm was chosen as a fair compromise between classification performance and computation requirement, in harmony with the microcontroller processing unit used in the following step of this study. A well-known MPR processing chain was used [20], and four popular time domain features were selected: mean absolute value, slope changes, zero crossings and waveform length [21].

B. PROSTHETIC SYSTEM

After confirming the possibility of intuitive MPR-based control by the congenital subject, and finding the optimal electrodes placement and movements, we continued to the realization of the MPR prosthetic system composed of a custom-made socket, a controller, and a prosthetic hand.

The socket was tailor-made for the subject's stump and provided with six bipolar EMG electrodes according to previously determined optimal placements (Figure 3). The prosthetic hand used was an iLimb-Ultra (Touch Bionics, United Kingdom), which the subject had used for two months prior the experiment. We utilized a retrofitted pattern recognition control system known as the Artificial Limb Controller [22]. The system contains an ADS1299 as analog-front-end for signal acquisition (eight bipolar channels), and an ARM Cortex-M4 based microcontroller as the main processing unit. It includes a SD card and an inertial sensors unit. Bluetooth link can be achieved by plugging an external dongle. The Artificial Limb Controller included a software library allowing signal pre-processing and acquisition, windowing and features extraction, pattern classification, and motor

control. EMG signals from electrodes mounted on the socket were acquired at a sampling frequency of 1000 Hz. Samples were gathered in sliding time windows of 100 ms with 50 ms time increment, hence, a new classification was performed every 50 ms. These parameters were chosen empirically and according to the discussion by Farrell [23]. The algorithm for classification and the selected features were the same as previously used during the MPR feasibility study.

In MPR, a prosthetic movement is usually performed incrementally for each classification and consecutive predictions of the aimed movement eventually lead to the intended position. This strategy is well suited for a virtual environment as well as advanced experimental prosthetic hands where single finger control can be achieved. However, such implementation of pattern recognition on a commercially available multi-grip prosthetic hand would require access to the manufacturers' communication interface. In the usual operation of these devices, the different grips are selected as finite states, and the final position of the fingers is reached without interruptions as a unique synergistic activation of motors. Once a grip posture has been reached, which takes a couple of seconds, further operation of that grip is performed with open/close commands managed via standard DC. Although incremental activation to reach a desired position is commonly used for hand open/close in DC, misclassifications pose a larger problem for grip selection because a single error can bring the hand to undesired postures causing a considerable delay before the hand can be repositioned. Therefore, a more robust strategy for grips classification was deemed necessary. Similar to the strategy proposed by Englehart and Hudgins [20], we implemented a buffer system that employs majority voting to mitigate misclassifications. Open and close were executed as encountered, whereas the grips used a majority voting algorithm with a buffer length of 11, which corresponded to 0.55 seconds delay. Proportional activation for hand open and close was implemented using the mean absolute value of the most active channel per movement, analogously to standard DC.

C. MPR-BASED GRIPS SWITCHING IN THE MULTIFUNCTIONAL HAND

The iLimb-Ultra allowed four different grips achievable by doing preconfigured patterns: hold open, co-contraction, double open impulse, and triple open impulse. These patterns encoded the postures open palm, side grip, fine grip and pointer, respectively. The MPR controller worked as a translational circuit in a semi-sequential trend, operating the iLimb-Ultra according to the predicted posture (Figure 1-a). Hence, each predicted movement was sent to the hand encoding the specific pattern (for example, a double impulse if the pointer posture won the majority voting). It is worthy of notice that the transactional logic did not include the open palm posture as another class in the MPR system. Instead, it was preferred to keep it as in the original iLimb-Ultra implementation, that is, achievable by holding an open hand command after

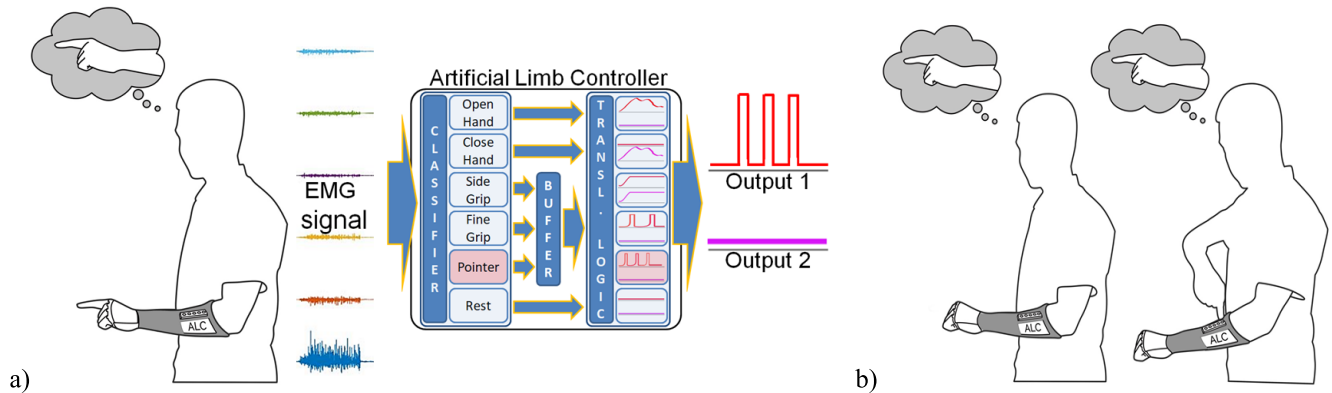

FIGURE 1. a) Representation of the MPR-based system to control the multifunctional prosthetic hand. The prosthesis allows four different grips achievable by doing preconfigured patterns: hold open, co-contraction, a double open impulse, and a triple open impulse. These patterns encoded the grips open palm, side grip, fine grip and pointer respectively. The MPR controller (Artificial Limb Controller) worked as a translational circuit in a semi-sequential trend, operating the hand according to the predicted posture. Each grip was then operated via proportional open and close hand movements. A majority vote buffer was used to reduce misclassifications. b) Representation of the error signaling system implemented for the Continuous Monitoring test. An array of buttons was placed on the outer socket of the prosthetic. In case of perceived misclassification, pressing an error button puts the controller in a temporary stand-by state forcing it to wait for the user to indicate the desired movement which was wrongly executed. The system then saves the occurrence of the error and the intended movement.

the current grip has reached full extension. This was done following the subject preference as the open palm movement is intuitively connected to opening of the hand.

D. REAL-TIME PERFORMANCE

In this study, we propose a novel method to estimate real-time MPR accuracy within a daily usage context. This approach is highly user-dependent and based on error markers stored in a SD card by using a button array directly connected to the main processing unit (Figure 1-b). Buttons were placed on the outer socket of the prosthetic. In case of misclassification, pressing an error button put the system in a temporary stand-by state forcing it to wait for the user to indicate the correct intended movement. It then marked that an error had occurred, and what the intended movement was. In this way, the ground-truth label could be associated to the error event and utilized during post-analysis to estimate accuracy. Logging of the rest state error was not provided, since a compromise was necessary due to hardware constraints. Moreover, to guarantee a later investigation into error prevalence and possible sources of errors, relevant data were continuously logged on the SD card. Triggered by classification time (50 ms), the system stored data such as classified movement, majority voting buffer state, and all extracted features for every channel. Considering that the rest state (no movement) classifications would have taken a strong dominance over all other movements, we decided to exclude it from the continuous log to place the system under less strain.

E. CONTINUOUS MONITORING TEST

The subject utilized the MPR system in his daily life for five consecutive days, and was instructed to properly log any situation where the prosthetic output was inconsistent with his own intention. Each test day began with training the MPR system with a new recording consisting of three repetitions

for each movement. The contraction time was three seconds with three seconds of rest.

As proposed by Fougner *et al.* [24], each movement was performed in different spatial positions. For the first contraction, the limb was extended forward at a 0° angle with respect to the perpendicular direction of the user's chest. For the second contraction, the limb was positioned at a 45° angle up from the previous position, and for the third contraction, the limb extended up along user's chest at a 90° angle from the initial position. At the end of each day, the system was connected to a computer to download the collected data. After the Continuous Monitoring test was completed, the challenge was to properly deal with the large amount of data available from the logging system. The task was not trivial considering that the data included both continuous instantly-executed movements (open/close), and movements instigated by winning a majority voting (grips).

For this reason, two main confusion matrices were extracted from the logged data: one taking into account all classifications made by the controller (*classification matrix*), and one considering the movements that were actually executed by the prosthesis (*execution matrix*). It is worth noting that by "executed movement" we refer to movements that were commanded by the controller and perceived by the user as executed by the prosthesis, i.e., if a prosthesis movement was not noticed by the user as incorrect, it was not counted as an error in the execution matrix. The rationale of adopting the execution matrix was to show the control accuracy from the user's perspective. The data analysis process was divided into sequential steps, where each one took into account a particular contribution. Data already accounted in one step were neglected in the next ones.

Firstly, the error marks were analyzed. Even though each mark reported the ground-truth of the related misclassification, defined as the intended movement, the challenge

was to identify which movement was erroneously executed instead, since the possibility to log this information was not available. For *classification* and *execution* matrices, our approach was to scan the data up to three seconds prior to each marker. In the case of the *classification matrix*, each classification within the three seconds contributed as a pair of intended/classified movements. For the *execution matrix*, we searched for the most prominent classified movement (different from the real intention of the user) within the three seconds, and we deemed that class as the perceived wrong execution. Thus, each logged error mark contributed with a single pair of intended/executed movement.

Secondly, we analyzed the grips classifications. This step required the analysis of all majority voting buffers registered by the controller. The winners of these buffers were assumed as correct, supported by the idea that the data was far enough from any reported error, which were accounted for in the previous step. Consequently, for the *execution matrix*, each buffer was considered as one true positive. In the case of the *classification matrix*, every classification happened within the same group contributed as paired with the class that eventually won the same group.

Thirdly, we accounted the remaining open and close movements as correct. For the *execution matrix* each series of open or close predictions was considered as a unique prosthesis activation event, contributing to the matrix as one true positive.

The aforementioned procedure allowed for an approximate characterization of the data available from the Continuous Monitoring test, with regard to both classification accuracy and prosthetic execution success. Each movement classification and/or execution was assigned to one of the following categories for each class of movement: true positive (TP), true negative (TN), false positive (FP) and false negative (FN). Consequently, the following class-specific metrics typical for machine learning problems were calculated: accuracy, specificity, sensitivity, precision and negative predicted value (NPV).

$$Accuracy = \frac{\Sigma TP + \Sigma TN}{\Sigma TP + \Sigma TN + \Sigma FP + \Sigma FN}$$

$$Specificity = \frac{\Sigma TN}{\Sigma TN + \Sigma FP}$$

$$Sensitivity = \frac{\Sigma TP}{\Sigma TP + \Sigma FN}$$

$$Precision = \frac{\Sigma TP}{\Sigma TP + \Sigma FP}$$

$$NPV = \frac{\Sigma TN}{\Sigma TN + \Sigma FN}$$

In the case of multi-class classification, as in MPR, the standard definition of accuracy is often misleadingly high due to the abundance of true negatives [25]. Therefore, in the field of MPR, accuracy is normally defined as:

$$MPR Accuracy = \frac{absolute\ correct\ classifications}{total\ absolute\ correct\ classifications}$$

where an “absolute correct classification” means that each of the classes involved was correctly classified (no FP nor FN in the binary string).

After that all classifications logged during the Continuous Monitoring test were labelled as correct or incorrect, a multinomial logistic regression algorithm was used to validate the reliability of our self-imposed labels. The different movement classes appeared in highly misbalanced quantities along the days of the experiment, therefore a statistical sampling was necessary to create balanced training and validation sets for the multinomial logistic regression algorithm. The number of representative samples from each class was imposed by the class having the lowest amount of samples. The training and validation sets were generated for both the absolute correct (TPs) and the absolute incorrect (FPs and FNs) classifications. During the validation phase, samples were fed to the regression algorithm and the estimated probabilities generated. The probabilities were then analyzed in terms of their distributions and their 95% confidence intervals. The multinomial logistic regression was applied individually to the data from each day, and globally merging all data available.

F. FUNCTIONALITY ASSESSMENT

Functionality tests were employed for comparative analysis of MPR and direct control approaches through an objective evaluation. The literature revealed several adequate assessment tools [26], [27], such as, the Assessment of Capacity for Myoelectric Control (ACMC) [28], the Activities Measure for Upper Limb Amputees [29], the Southampton Hand Assessment Procedure [30], and the University of New Brunswick Test [31]. Given its high validity and easy accessibility, the ACMC was deemed as the most appropriate test in this study. It includes 22 gripping, releasing, holding, and coordinating items that the patients can perform within the context of a functional activity that is considered to be meaningful to them. All items are rated on a four-point rating scale: 0 = not capable, 1 = somewhat capable, 2 = generally capable, and 3 = extremely capable. Three functional activities were included here (Figure 8): 1) building a ready-to-assemble project (a lamp), 2) wrapping a present and writing a gift card, and 3) setting up a table for six people. The ACMC test was conducted alternating the two control methods over each activity. It was decided to start each activity with the MPR method, thus tasks were more familiar to the subject when performing in DC. The test was performed over one full day planned two weeks after the Continuous Monitoring test was over. Due to the time availability of the single subject involved, it was not possible to repeat the ACMC more than once per control method. An occupational therapist organized the tests, giving instructions while recording the performance on video. Evaluation and review was done by a second occupational therapist without knowledge of what control method was being used in each recording. The subject was instructed to conduct the tasks in MPR mode without logging errors in case any occurred.



FIGURE 2. Movements investigated using myoelectric pattern recognition.

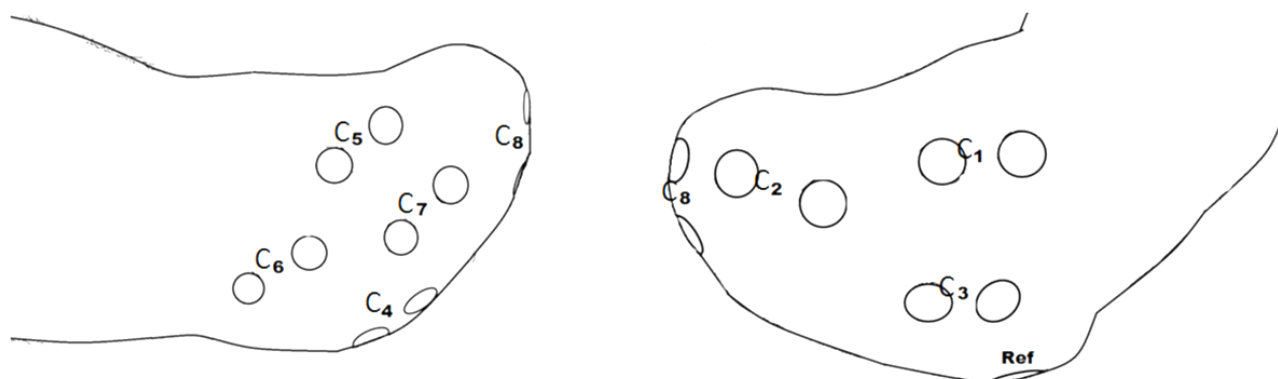

FIGURE 3. Electrode placement over the transradial dysmelia subject’s residual limb, inner (left) and outer (right) sides. The reference electrode was placed on the bony part of the elbow.

IV. RESULTS

A. ELECTRODES PLACEMENT AND MPR

Using high-density surface EMG, we identified eight bipolar electrode locations for MPR (Figure 3). Reference electrode was placed on the elbow. The investigated movements are depicted in Figure 2, named from M1 to M7. The Motion Tests from the first six-day test session allowed us to find two potentially viable combinations:

1. Seven movements (M1 to M7 plus rest state) with eight channels (C1 to C8, plus the reference);
2. Five movements (M1 to M5 plus rest state) with six channels (C1 to C6, plus the reference).

These combinations were then tested during the second six-day session and the results are shown in Figure 4. Based on these results, the five movements/six electrodes setup was deemed preferable given better online accuracy, completion times, and rates for most movements; hence, it was chosen for the socket implementation and the Continuous Monitoring test.

B. CONTINUOUS MONITORING TEST

The Continuous Monitoring test lasted five days with a mean utilization time of the prosthesis of around seven hours per day (summary in Table 1). The activity per day of the embedded classification algorithm is reported in Table 2. The total amount of reported errors normalized to the usage hours are shown in Figure 5. The extracted classification and execution

TABLE 1. Prosthesis usage during the continuous monitoring test.

Day	Usage time [hrs]	On/Off [#]	Active time [hrs]	Reported Errors [#]	Errors per hour
1	8.5	5	0.23	51	5.98
2	8.3	5	0.29	31	3.75
3	7.5	3	0.22	30	4.03
4	5.4	0	0.31	26	4.78
5	3.9	9	0.29	16	4.15

confusion matrices are depicted in Figure 7 and they are integrated with the class-specific metrics reported in Table 3. The false negative values regarding the *execution matrix* on Table 3 represent the total amount of manually logged errors per movement. Table 4 reports the confidence intervals of the distributions of probability estimated with multinomial logistic regression for validating the post-analysis labels. Figure 6 reports main information related to the utilization of the open and close hand movements, defined previously as continuous proportional movements.

C. FUNCTIONALITY ASSESSMENT

Scores from the ACMC test are reported in Table 5. ACMC scores were within a 0-to-100 scale, where 100 represents the user being extremely capable of controlling a myoelectric prosthesis. Minimal detectable change in the same assessor was 2.5 units. Table 5 also reports those items which had

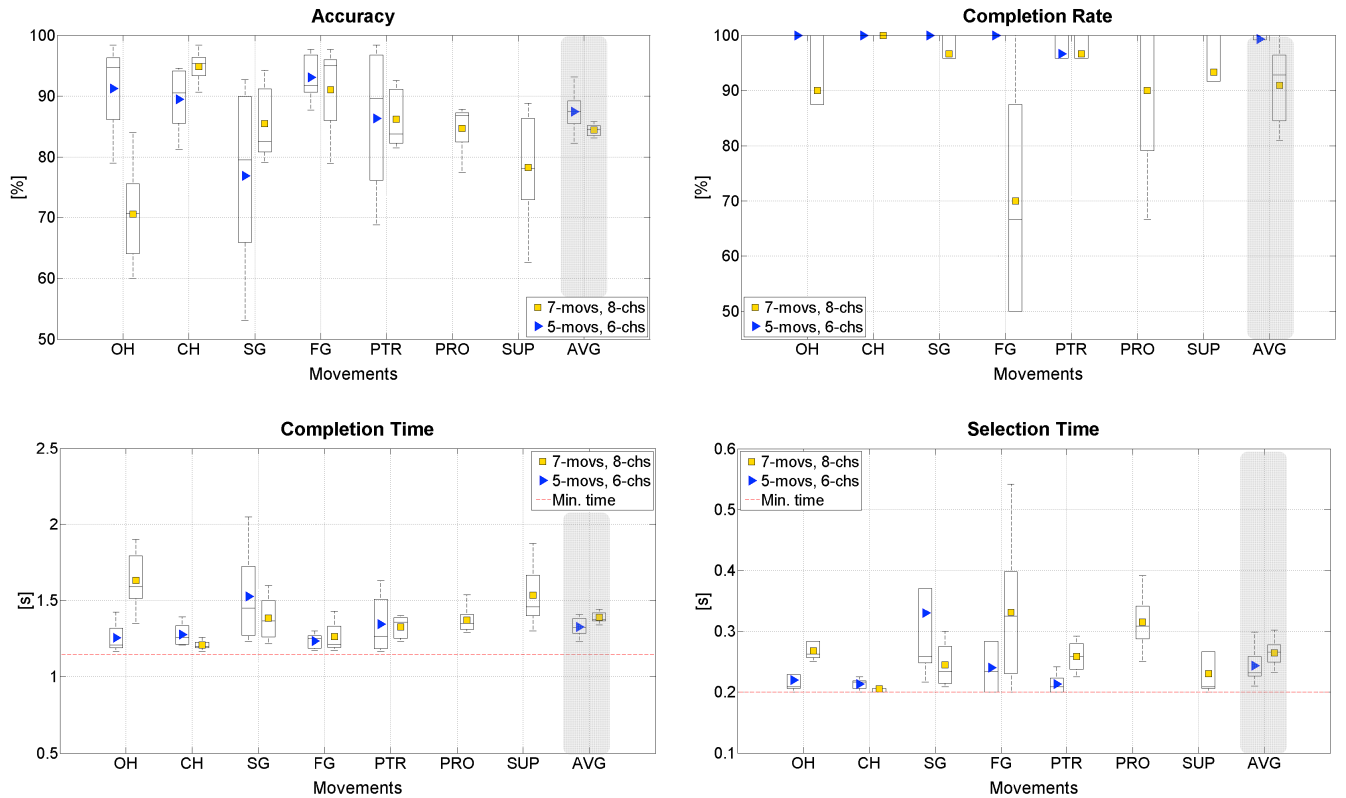

FIGURE 4. Validation of real-time myoelectric pattern recognition on the dysmelia subject. Results of the Motion Test for different channels/movements configurations (OH = open hand, CH = close hand, SG = side grip, FG = fine grip, PTR = pointer, PRO = pronation, SUP = supination, AVG = average). The symbol and the line in the boxplots represent the mean and median of each box, respectively. Accuracy was calculated using the predictions during the completion time, and only completed motions contributed. Completion Rate is the rate of successful trials. Completion Time is the time to reach 20 correct predictions. Selection Time is the time required to reach the first correct prediction.

TABLE 2. Number of classified/executed movements during the continuous monitoring test.

Day	Continuous Movements		Buffered Movements					
	Open	Close	Classified			Executed		
			Side	Fine	Pointer	Side	Fine	Pointer
1	3494	6258	1466	2687	2659	102	114	83
2	3164	8509	1726	4991	2332	98	140	91
3	2700	9223	806	2196	971	44	83	30
4	1716	8106	770	9384	2400	47	320	26
5	4521	9250	1044	5123	850	52	126	16

different scores between the two control methods. Brief comments from the occupational therapist included that, during DC, the prosthesis was used in more positions with better timing in both opening and closing, and also that the user tended to focus less on the prosthetic equipment in comparison to MPR control.

V. DISCUSSION

A. EMG ELECTRODES FOR MPR

In general, higher number of EMG electrodes leads to higher accuracy for MPR. However, this fairly intuitive conclusion might not equally translate in an out-of-the-lab context where the displacement of a single electrode, caused by the user moving around and interacting with objects, could potentially decrease the accuracy by 10% [12]. When exploring

the viable configurations for the MPR system, the added benefits of the eight electrodes configuration seemed to be related to only wrist rotation movements. Moreover, the two extra electrodes (C7 and C8) were positioned in spots with high residual limb movements that could have resulted in more pronounced electrode shifts and artifacts during daily life usage. Higher controllability was preferred over more prosthesis degrees of freedom, a conclusion that was also supported by the Motion Tests results. Therefore, our setup choice converged to the six electrodes and five movements.

B. REAL-TIME TEST

Probably one of the most innovative aspects of this study is the proposed method to estimate real-time classification accuracy. Despite being substantially user-dependent,

TABLE 3. Class-specific metrics for classification (top) and execution (bottom) confusion matrices.

Class	True Positive [#]	True Negative [#]	False Positive [#]	False Negative [#]	Accuracy [%]	MPR Accuracy [%]	Specificity [%]	Sensitivity [%]	Precision [%]	NPV [%]
Open	11505	88273	3437	3102	93.9	78.8	96.3	78.8	77.0	96.6
Close	35005	59938	6070	5304	89.3	86.8	90.8	86.8	85.2	91.9
Side Grip	3130	99612	1716	1859	96.6	62.7	98.3	62.7	64.6	98.2
Fine Grip	22680	67581	6723	9333	84.9	70.8	90.9	70.8	77.1	87.9
Pointer	3819	94753	3326	4419	92.7	46.4	96.6	46.4	53.5	95.5

Class	True Positive [#]	True Negative [#]	False Positive [#]	False Negative [#]	Accuracy [%]	MPR Accuracy [%]	Specificity [%]	Sensitivity [%]	Precision [%]	NPV [%]
Open	1065	3532	19	79	97.9	93.1	99.5	93.1	98.3	97.8
Close	2192	2436	28	39	98.6	98.3	98.9	98.3	98.7	98.4
Side Grip	304	4358	21	12	99.3	96.2	99.5	96.2	93.5	99.7
Fine Grip	716	3931	36	12	99.0	98.4	99.1	98.4	95.2	99.7
Pointer	264	4369	50	12	98.7	95.7	98.9	95.7	84.1	99.7

TABLE 4. Confidence Intervals ($Z_{0.025}$) of probabilities estimated with multinomial logistic regression analysis Absolute Correct Classifications (top) and Absolute Incorrect Classifications (bottom).

Class	Day 1	Day 2	Day 3	Day 4	Day 5	Global
Open	(0.77, 0.83)	(0.78, 0.82)	(0.79, 0.83)	(0.78, 0.81)	(0.78, 0.81)	(0.80, 0.83)
Close	(0.85, 0.90)	(0.85, 0.88)	(0.86, 0.89)	(0.85, 0.88)	(0.85, 0.87)	(0.82, 0.85)
Side Grip	(0.93, 0.96)	(0.93, 0.95)	(0.93, 0.95)	(0.94, 0.96)	(0.94, 0.96)	(0.93, 0.95)
Fine Grip	(0.85, 0.90)	(0.86, 0.90)	(0.87, 0.90)	(0.85, 0.88)	(0.84, 0.87)	(0.82, 0.85)
Pointer	(0.79, 0.86)	(0.80, 0.84)	(0.82, 0.86)	(0.79, 0.83)	(0.81, 0.84)	(0.85, 0.88)

Class	Day 1	Day 2	Day 3	Day 4	Day 5	Global
Open	(0.71, 0.76)	(0.70, 0.73)	(0.71, 0.74)	(0.72, 0.75)	(0.72, 0.74)	(0.71, 0.79)
Close	(0.65, 0.70)	(0.67, 0.71)	(0.68, 0.72)	(0.68, 0.71)	(0.66, 0.69)	(0.63, 0.70)
Side Grip	(0.67, 0.73)	(0.69, 0.73)	(0.72, 0.76)	(0.75, 0.78)	(0.75, 0.77)	(0.72, 0.78)
Fine Grip	(0.68, 0.74)	(0.70, 0.74)	(0.70, 0.75)	(0.65, 0.68)	(0.64, 0.67)	(0.58, 0.66)
Pointer	(0.40, 0.48)	(0.41, 0.46)	(0.44, 0.49)	(0.40, 0.44)	(0.40, 0.43)	(0.32, 0.39)

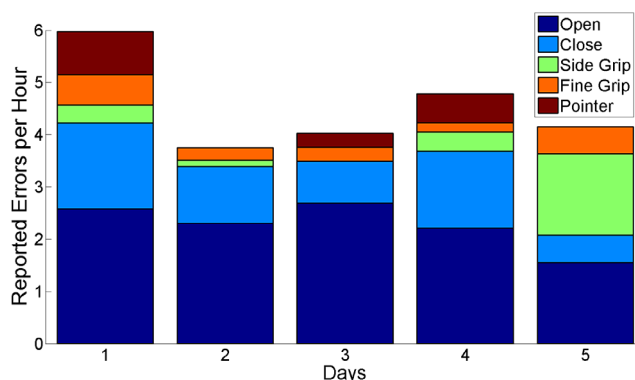

FIGURE 5. Amount of manually reported errors per hour over the five days of the Continuous Monitoring test.

it resulted in being relatively precise and tolerated by the user. Although the manual logging of errors can be perceived as a burdensome task, the benefits of obtaining

reliable information were deemed superior to the inconvenience imposed on the user, who ultimately tolerated well the additional burden. This approach of logging information can give access to a useful source of data for statistics about the performance of the system, and moreover, it could be used to reinforce on-the-fly the training of the classification algorithm. A less cumbersome array of buttons would be needed if this approach is to be used for a final prosthetic system. Some difficulties were found during the post-analysis of data, especially when searching for the source of errors. The analysis could be simplified by allowing the user to input also the perceived misclassified movement together with the intended one.

In a standard offline validation phase of a pattern recognition algorithm, the test samples are usually balanced between all the different classes. This means that, each class is usually represented by the same number of test samples. Conversely, in a real-time experiment in an uncontrolled environment, this is not the case. As expected, the movements' distribution in

TABLE 5. ACMC scores: items with different scores between MPR and DC, and overall scores.

Activity Item / Control Method	Building a Lamp		Wrapping a Present		Setting Up a Table	
	MPR	DC	MPR	DC	MPR	DC
Grip in different positions	2	3	1	3		
Grip with timing			1	2		
Grip coordination between hands					3	2
Grip without visual feedback	0	1				
Grip force without visual feedback	0	3				
Re-adjust grip			2	3		
Re-adjust grip without visual feedback	0	2	0	1		
Holding in motion					3	2
Release in different positions	2	3				
Release in timing	1	2				
ACMC measure (sum of raw scores)	62.0 (51)	74.3 (60)	66.4 (55)	74.3 (60)	66.4 (55)	64.1 (53)

Average duration time and muscular effort for series of continuous movements

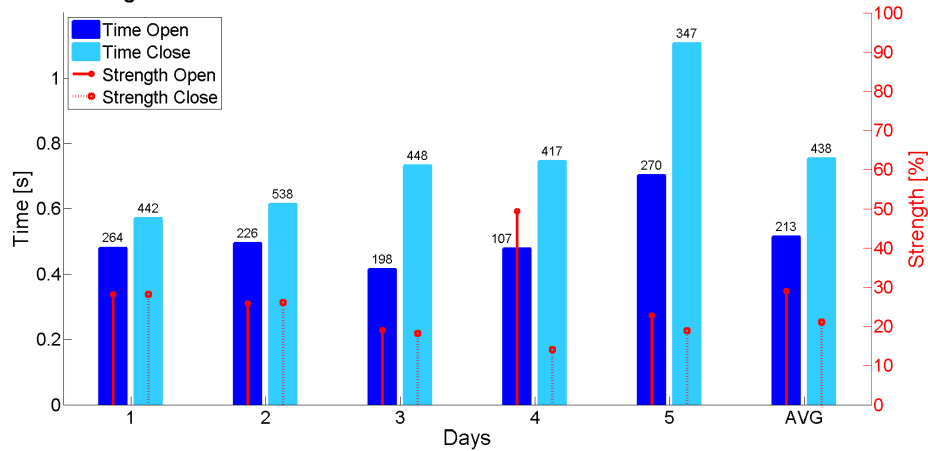

FIGURE 6. Average duration time and muscular effort for series of continuous proportional movements (open and close hand). The numbers above the bars represent the amount of series registered for that particular movement along that day. The strength was calculated over the mean absolute value as the averaged proportional value to the maximum registered value (averaged between all channels) over all days.

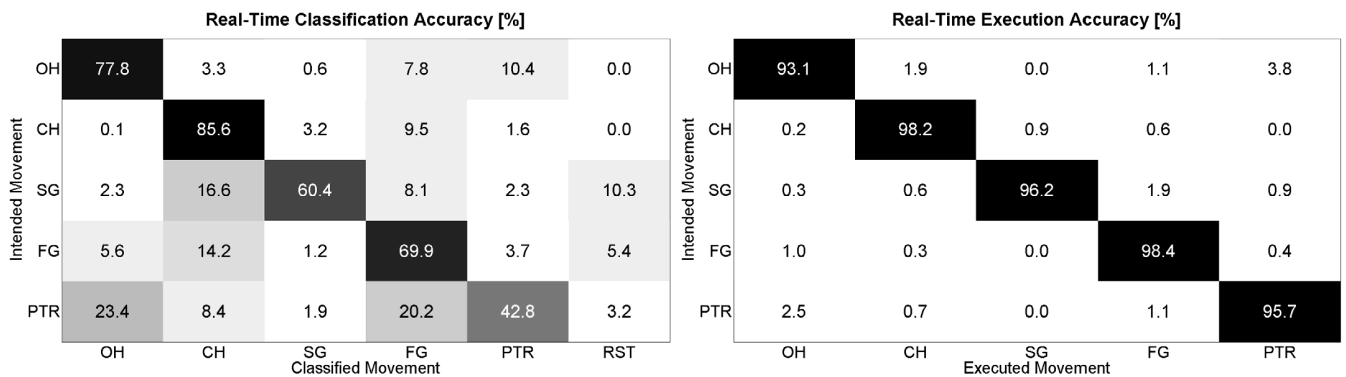

FIGURE 7. Real-time myoelectric pattern recognition accuracy. Confusion matrices, for classification (left) and execution (right), resulted from post-analysis of the data logged during the Continuous Monitoring test. All values are presented in percentage (OH = open hand, CH = close hand, SG = side grip, FG = fine grip, PTR = pointer, RST = rest).

our study was heavily unbalanced. Rest state classifications were the most prominent, and besides a few exceptions, were all correct. Moreover, continuous open and close hand movements appeared in substantially larger numbers compared to

the various grips. Provided these considerations, the resulting global accuracy was basically meaningless in this context. A confusion matrix alone can be misleading and should be seen only as an indication of what happened in the controller.



FIGURE 8. Assessment of Capacity for Myoelectric Control (ACMC). The figures show the three functional tasks involved in the test: building a ready-to-assemble lamp project (a lamp), wrapping a present and writing a gift card, and setting up a table for six people.

This motivated the need to integrate the results with class-specific performance metrics. For this reason, all values of true and false positives and negatives were reported for each class, together with common metrics based on these factors.

The multinomial logistic regression allowed for the validation of the correct and incorrect labels imposed at the post-analysis of the data collected during the Continuous Monitoring test. The estimated probabilities resulted similar and stable along the various days of test. High separability between classes was confirmed for those samples labelled as absolute correct. The classes separability considerably decreased within those samples labelled as absolute incorrect, inherently confirming that those predictions were actually misclassifications properly labelled as errors during post-analysis.

The confusion matrices in Figure 7 matched the user reports after the daily life test. The user reported “open hand misclassified as pointer”, as the most common perceived failure of the prosthesis, and to a much lesser extent “close hand misclassified as fine grip”. Arguably, the difficulties encountered in the classification of these pairs were due to the similarity in myoelectric signals generated by these movements. The pointer grip involves extensor muscles similarly to hand open, and fine (and side) grip requires a partial flexion of the fingers, similarly to close hand. Visual inspections of the EMG signals confirm the similarity of these movements. This arises ultimately from the surface electrodes noninvasive nature, where skin impedance, arm position, and neighboring muscles cross-talk contribute to poor signal quality. It must be pointed out that these results strictly relate to the classifying configuration used; more advanced signal processing, classification algorithms and feature combinations might provide more distinguishable data, and thus mitigate errors.

From Figure 5 an improvement trend can be identified during the five days of the Continuous Monitoring test, confirming the known benefit of user training for a better MPR performance.

As expected, the close hand movement was found to be most frequently engaged, and on average, it was used for longer periods of time and with less muscular effort

(Figure 6). The user reported the close hand command to be more dominant compared to the opposite open hand, as confirmed from the results. Intuitively, any object manipulation requires usually more focus in the grasping phase, thus the prosthesis is engaged more frequently with slower executions. Alternatively, the item reaching phase is usually accompanied by fast and powerful open hand activations to extend the fingers and prepare the prosthesis for the grasp action.

A limitation of this pilot study was that only one subject was engaged. More extensive tests on a wider population are needed to generalize our findings.

C. GRIPS SWITCHING STRATEGY

A contribution of this study that might have certain clinical relevance was the method used to operate a multi-grip commercial prosthetic hand with posture selection made via pattern recognition. A post-processing algorithm acted as an interpreter between the classifier decisions and a commercially available, high-end prosthetic hand. The motivation was to facilitate the switching mechanism that drives the hand between different grips. This approach might extend the use of MPR in out-of-the-lab contexts.

The difference between the results shown in the confusion matrices for classification and execution brings the attention to the particular post-processing control algorithm implemented for the Continuous Monitoring test. The popular majority voting algorithm included only grips classification with an overall delay of decision that might be controversial with previous works in the field. It is important to note that this delay was found empirically accepted by the patient, and it was a compromise between an inconvenient utilization lag, and an acceptable mitigation of errors. This strategy not only reduced grip misclassification and their incidence on the prosthesis usability, but also provided fast and proportional control of each grip.

D. ACMC

The ACMC scores were high enough to deem the two control approaches “functional”. Unfortunately, the possible

learning effect makes it hard to properly compare the scores. When performing each activity with the DC approach, the tasks were already familiar to the subject. The test-retest reliability of the ACMC has been proven previously [32], but only considering subjects “able to exercise stable myoelectric control”, which is probably true for DC but not for MPR in the present study. This might explain why DC reported higher scores than MPR, mostly due to better timing and less discontinuation while performing tasks. Moreover, this might also explain the learning curve of MPR along the different activities which, with a decline in DC score, resulted in MPR scoring higher than DC in the last one. More subjects would have been certainly beneficial, for the aim of the comparative analysis, as well as performing the ACMC more than once per subject. Future comparative research with MPR using ACMC should be performed after a period of familiarization with the MPR system to achieve optimal results.

General comments from the occupational therapist and the test subject identified important differences between MPR and DC methods. When using MPR, there was a distrust using the open and close commands, arguably because they produced the highest amount of errors, even if their occurrence and frequency were relatively low. The distrust was reported by the subject, and confirmed by a stronger focus on the movements of the prosthesis under MPR. It is possible that the higher level of attention was related to the unfamiliarity with the test activity (the MPR condition was tested first). This possibly led the user to be cautious and limit the range of motion in order to prevent possible misclassification due to loss of skin-electrodes contact. For the grips, the perceived functionality between the control approaches was instead inverted. In fact, the user reported grasp selection operated via DC as unintuitive as opposed to pattern recognition that felt more natural and fast paced. This was a surprising result given that the user is a congenital amputee without any previous experience using a fully developed hand. Our results point to similar conclusions by Farina *et al.* [13], in which pattern recognition could be a viable option for some congenital amputees.

E. CHALLENGES FOR CLINICAL APPLICATIONS

Although signal similarity is a significant error source, it is far from being the only source. Many other external sources were identified; one of which is the design of the socket. During the virtual tests, the residual limb is treated as a static object, and surface EMG electrodes are not subjected to uneven or variable connectivity. During a normal day, the arm is subjected to varying amounts of load and shifts of the limb positions that will eventually lead to electrodes displacement. Even though this was not quantified, the user observed that a significant part of the errors occurred during arm motions, or in odd arm positions. Further evidence of this was found during the first preliminary tests of the whole prosthetic system; the electrode placed most distal to the elbow was found to not connect unless in specific angles. Its

disconnection caused major classification errors making the system almost unusable. The system stabilized after refitting the electrode. As reasoned by Fougner *et al.* [24], electrode displacements could be mitigated to some extent by varying limb positions during recording sessions. Moreover, simple artifacts removal algorithms or a more advanced wavelet filter, or temporarily “muting” the contribution of a channel found to be misconnected, could potentially solve this issue.

It is worthy of notice that in the last two days, the prosthesis was used for a shorter period of time, around 4.5 hours versus the average of eight hours of the other three days. This was due to a socket-fitting problem that eventually forced the user to stop the experiment after 5 days. The socket design was too tight, causing the socket to push too harshly around the elbow region and the ulnar nerve. This caused numbness in the forearm that turned into pain in the last day. These symptoms were alleviated few days after the subject wore his previous socket. In conclusion, the socket interface represents an important challenge to the translation of surface EMG based MPR systems to clinical use.

VI. CONCLUSION

In this work, we investigated the functionality of a pattern recognition system for controlling a multi-grip prosthetic hand during daily life. A self-contained prosthetic system composed of a custom-made socket, an embedded system capable of myoelectric pattern recognition, and a high-end prosthetic hand was developed. We proposed a novel method for interfacing the multi-grip prosthetic hand with myoelectric pattern recognition to facilitate posture selection. We utilized a user-oriented approach for estimating real-time classification accuracy based on direct feedback from the user via an array of buttons. A transradial dysmelia subject used this prosthetic system in his daily life for five consecutive days, while continuously logging errors as they emerged. The user reported relatively stable control of the prosthesis.

The results of the functionality tests together with the user’s comments raised concerns regarding accuracy and its relationship to user satisfaction. Finding suitable evaluation methods is imperative, especially now that clinical application of myoelectric pattern recognition is increasing. If a prosthetic hand drops a cup of hot coffee one every 100 times, could it be called trustworthy? It is our opinion that other methods to measure perceived functionality should be investigated towards more user-oriented prospective evaluations.

ACKNOWLEDGMENT

The authors would like to thank Stewe Jönsson, Jason Millenaar, Sonam Iqbal and Alejandra Zepeda for supporting along the socket and system realization, and illustrations. They would also like to thank Anita Stockselius for helping with the ACMC tests and analyses.

REFERENCES

- [1] R. W. Wirta, D. R. Taylor, and F. R. Finley, "Pattern-recognition arm prosthesis: A historical perspective—A final report," *Bull. Prosthetics Res.*, vol. 10, no. 30, pp. 8–35, 1978.
- [2] P. Herberts, C. Almström, R. Kadefors, and P. D. Lawrence, "Hand prosthesis control via myoelectric patterns," *Acta Orthopaedica Scand.*, vol. 44, nos. 4–5, pp. 389–409, 1973.
- [3] D. Graupe, W. J. Monlux, and I. Magnussen, "A multifunctional prosthesis control system based on time series identification of EMG signals using microprocessors," *Bull. Prosthetics Res.*, vol. 10, no. 27, pp. 4–16, 1977.
- [4] G.-C. Chang *et al.*, "Real-time implementation of electromyogram pattern recognition as a control command of man-machine interface," *Med. Eng. Phys.*, vol. 18, no. 7, pp. 529–537, Oct. 1996.
- [5] F. Tenore, R. S. Armiger, R. J. Vogelstein, D. S. Wenstrand, S. D. Harshbarger, and K. Englehart, "An embedded controller for a 7-degree of freedom prosthetic arm," in *Proc. Conf. IEEE EMBC*, Aug. 2008, pp. 185–188.
- [6] A. Boschmann, A. Agne, L. Witschen, G. Thombsen, F. Kraus, and M. Platzner, "FPGA-based acceleration of high density myoelectric signal processing," in *Proc. Conf. ReConFig*, Dec. 2015, pp. 1–8.
- [7] M. Rossi, C. D. Santina, C. Piazza, G. Grioli, M. Catalano, and A. Bicchi, "Preliminary results toward a naturally controlled multi-synergistic prosthetic hand," in *Proc. Conf. ICORR*, Jul. 2017, pp. 1356–1363.
- [8] S. Benatti, B. Milosevic, E. Farella, E. Gruppioni, and L. Benini, "A prosthetic hand body area controller based on efficient pattern recognition control strategies," *Sensors*, vol. 17, no. 4, p. 869, 2017.
- [9] S. L. Carey, D. J. Lura, and M. J. Highsmith, "Differences in myoelectric and body-powered upper-limb prostheses: Systematic literature review," *J. Res. Rehabil. Develop.*, vol. 52, no. 3, pp. 247–262, 2014.
- [10] L. H. Smith, T. A. Kuiken, and L. J. Hargrove, "Real-time simultaneous and proportional myoelectric control using intramuscular EMG," *J. Neural Eng.*, vol. 11, no. 6, p. 66013, 2014.
- [11] N. Jiang, T. Lorrain, and D. Farina, "A state-based, proportional myoelectric control method: Online validation and comparison with the clinical state-of-the-art," *J. Neuroeng. Rehabil.*, vol. 11, no. 1, p. 110, 2014.
- [12] A. O. Andrade *et al.*, "Bridging the gap between robotic technology and health care," *Biomed. Signal Process. Control*, vol. 10, no. 1, pp. 65–78, Mar. 2014.
- [13] D. Farina *et al.*, "The extraction of neural information from the surface EMG for the control of upper-limb prostheses: Emerging avenues and challenges," *IEEE Trans. Neural Syst. Rehabil. Eng.*, vol. 22, no. 4, pp. 797–809, Jul. 2014.
- [14] I. Vujaklija *et al.*, "Translating research on myoelectric control into clinics—Are the performance assessment methods adequate?" *Frontiers Neurobotics*, vol. 11, pp. 1–7, Feb. 2017.
- [15] C. Cipriani, J. L. Segil, J. A. Birdwell, and R. F. Weir, "Dexterous control of a prosthetic hand using fine-wire intramuscular electrodes in targeted extrinsic muscles," *IEEE Trans. Neural Syst. Rehabil. Eng.*, vol. 22, no. 4, pp. 828–836, Jul. 2014.
- [16] P. F. Pasquina *et al.*, "First-in-man demonstration of a fully implanted myoelectric sensors system to control an advanced electromechanical prosthetic hand," *J. Neurosci. Methods*, vol. 244, pp. 85–93, Apr. 2015.
- [17] M. Ortiz-Catalan, B. Håkansson, and R. Brånemark, "An osseointegrated human-machine gateway for long-term sensory feedback and motor control of artificial limbs," *Sci. Transl. Med.*, vol. 6, no. 257, p. 257re6, Oct. 2014.
- [18] T. A. Kuiken *et al.*, "Targeted muscle reinnervation for real-time myoelectric control of multifunction artificial arms," *J. Amer. Med. Assoc.*, vol. 301, pp. 619–628, Feb. 2009.
- [19] M. Ortiz-Catalan, R. Brånemark, and B. Håkansson, "BioPatRec: A modular research platform for the control of artificial limbs based on pattern recognition algorithms," *Sour. Code Biol. Med.*, vol. 8, p. 11, Apr. 2013.
- [20] K. Englehart and B. Hudgins, "A robust, real-time control scheme for multifunction myoelectric control," *IEEE Trans. Biomed. Eng.*, vol. 50, no. 7, pp. 848–854, Jul. 2003.
- [21] B. Hudgins, P. Parker, and R. N. Scott, "A new strategy for multifunction myoelectric control," *IEEE Trans. Biomed. Eng.*, vol. 40, no. 1, pp. 82–94, Jan. 1993.
- [22] E. Mastinu, P. Doguet, Y. Botquin, B. Håkansson, and M. Ortiz-Catalan, "Embedded system for prosthetic control using implanted neuromuscular interfaces accessed via an Osseointegrated implant," *IEEE Trans. Biomed. Circuits Syst.*, vol. 11, no. 4, pp. 867–877, Aug. 2017.
- [23] T. R. Farrell, "Determining delay created by multifunctional prosthesis controllers," *J. Rehabil. Res. Develop.*, vol. 48, no. 6, pp. 21–38, 2011.
- [24] A. Fougner, E. Scheme, A. D. C. Chan, K. Englehart, and Ø. Stavaahl, "Resolving the limb position effect in myoelectric pattern recognition," *IEEE Trans. Neural Syst. Rehabil. Eng.*, vol. 19, no. 6, pp. 644–651, Dec. 2011.
- [25] M. Ortiz-Catalan, F. Rouhani, R. Brånemark, and B. Håkansson, "Offline accuracy: A potentially misleading metric in myoelectric pattern recognition for prosthetic control," in *Proc. Conf. IEEE EMBC*, Aug. 2015, pp. 1140–1143.
- [26] V. Wright, "Prosthetic outcome measures for use with upper limb amputees: A systematic review of the peer-reviewed literature, 1970 to 2009," *JPO J. Prosthetics Orthotics*, vol. 21, no. 9, pp. P3–P63, 2009.
- [27] L. Resnik, M. Borgia, B. Silver, and J. Cancio, "Systematic review of measures of impairment and activity limitation for persons with upper limb trauma and amputation," *Arch. Phys. Med. Rehabil.*, vol. 98, no. 9, pp. 1863–1892, Sep. 2017.
- [28] L. M. Hermansson, A. G. Fisher, B. Bernspång, and A.-C. Eliasson, "Assessment of capacity for myoelectric control: A new Rasch-built measure of prosthetic hand control," *J. Rehabil. Med.*, vol. 37, no. 3, pp. 166–171, 2005.
- [29] L. Resnik *et al.*, "Development and evaluation of the activities measure for upper limb amputees," *Arch. Phys. Med. Rehabil.*, vol. 94, no. 3, pp. 488–494, 2013.
- [30] C. M. Light, P. H. Chappell, and P. J. Kyberd, "Establishing a standardized clinical assessment tool of pathologic and prosthetic hand function: Normative data, reliability, and validity," *Arch. Phys. Med. Rehabil.*, vol. 83, no. 6, pp. 776–783, Jun. 2002.
- [31] E. R. Sanderson and R. N. Scott, "UNB test of prosthetics function: A test for unilateral upper extremity amputees, ages 2–13," Dept. Bio-Eng. Inst., Univ. New Brunswick, Fredericton and Saint John, NB, Canada, Tech. Rep., 1985.
- [32] H. Y. N. Lindner, A. Langius-Eklöf, and L. M. N. Hermansson, "Test-retest reliability and rater agreements of assessment of capacity for myoelectric control version 2.0," *J. Rehabil. Res. Develop.*, vol. 51, no. 4, pp. 635–644, 2014.